

PLAN VIEW

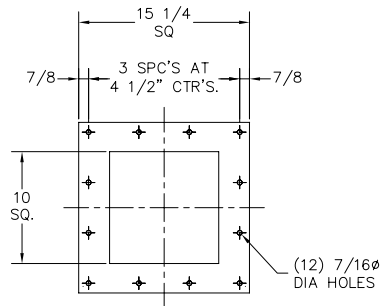

FLANGE DETAIL

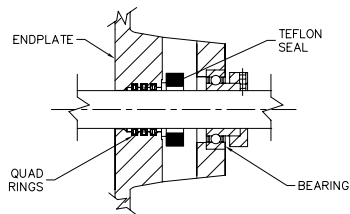

ACST-4 SEAL DETAIL

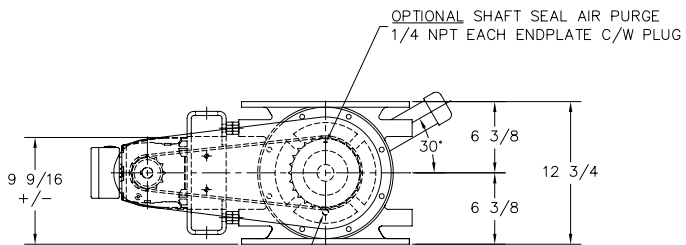

ELEVATION

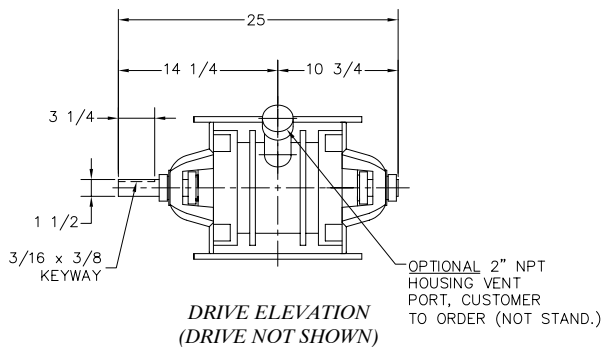

DRIVE ELEVATION
(DRIVE NOT SHOWN)

VALVE INFORMATION					
HOUSING	ENDPLATE	ROTOR	BLADE TIP		
MAT'L	MAT'L	MAT'L	TYPE	MAT'L	CLEARANCE
C.I.	C.I.	MILD STEEL	FIXED EDGE	MILD STEEL	.004-.007

MOTOR						
MFG.	H.P.	VOLTAGE	ENCLOSURE	CL. & DIV.	FRAME SIZE	RPM
SEW EURODRIVE R-SERIES	3/4	T.B.A.	TEFC	STD. EFF.	DT80N4	1800

REDUCER				
MFG.	FRAME	RATIO	SIZE	R.P.M.
GEARMOTOR	R37	36.72	R37DT80N4	46

CHAIN DRIVE				VALVE OPERATING CONDITIONS	
SIZE	BORE	SIZE	BORE	TEMP.	SEALS
60B12	1Ø	60B26	1 1/2Ø	AMBIENT	ACST-4

CONVEYING INFORMATION	
PRODUCT HANDLED	TO BE ADVISED
PRODUCT DENSITY	TO BE ADVISED
DISPLACEMENT / REV. 100%	.40 C.F.R.
VALVE SPEED	20 RPM
CONVEY RATE	TO BE ADVISED

NOTES

- ALL DIMENSIONS IN INCHES
- CONSTRUCTION: CAST GREY IRON HOUSING AND ENDPLATES (CL,40,217 BRINELL) FABRICATED CARBON STEEL ROTOR, OPEN END FIXED WITH RELIEVED TIPS (1/8" LAND) CLOSE TOLERANCE C.C.W. ROTATION LOOKING AT THE DRIVE END.
- BOTTOM FLANGE BOLT PATTERN MATCHES TOP FLANGE PATTERN
- PAINT: STANDARD METAL PREPARATION, EXTERIOR PRIMED AND ONE COAT FINISH ENAMEL - ACS BLUE DRIVE GUARD IS HI-VISIBILITY SAFETY YELLOW, MOTOR/GEARMOTOR IS MANUFACTURES STANDARD FINSH
- ACST-4 SHAFT SEAL ASSEMBLY (SEE DETAIL)
- WEIGHT WITH DRIVE PACKAGE 400 LBS.
- INCLUDED OPTIONS:
 - ENDPLATES: SHAFT SEAL ASSEMBLY AIR PURGE CONNECTION, 1/4" NPT
 - ENDPLATES: CAST IRON CONSTRUCTION
 - ROTOR: FABRICATED OPEN END MILD STEEL
 - ROTOR: FIXED EDGE MILD STEEL ROTOR TIPS - BEVELED
 - HOUSING: CAST IRON CONSTRUCTION

ACS
VALVES

611 ARGYLE STEET NORTH
CALEDONIA ONT. N3W-1M1

PHONE: 905-765-2004
FAX: 905-765-4491

sales@ancasterconveying.com
www.ancasterconveying.com

TITLE: ACS MODEL MODEL C.I. 10 X 10 ROTARY VALVE, GENERAL ARRANGEMENT

FOR: GENERAL USE ONLY

P.O: N/A

SCALE: N.T.S. DRAWN BY: G.T

DATE: MAR/24/09 CHECKED:

B-2251-DP

Proprietary Information
This drawing is the confidential property of Ancaster Conveying Systems Ltd. and transmitted in confidence. The reproduction, use or disclosure, in whole or in part, of the design or details contained herein is prohibited without the express written permission of Ancaster Conveying Systems Inc.

ISSUE	DATE	REVISION	BY