

STANDARD FLANGE PATTERN

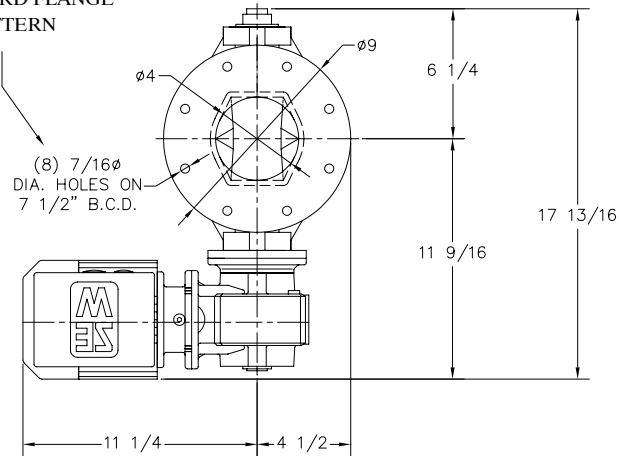

PLAN VIEW

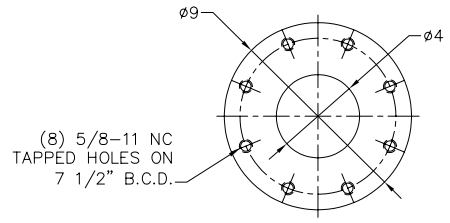

150# FLANGE PATTERN (OPTIONAL)

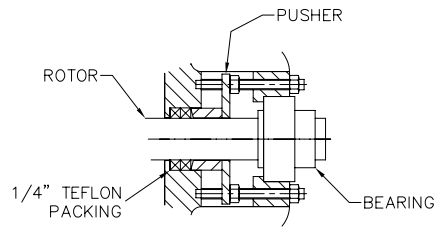

PUSH TYPE SEAL ASSEMBLY

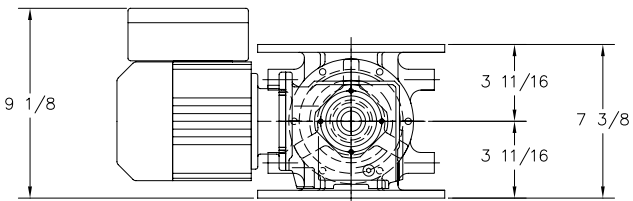

ELEVATION

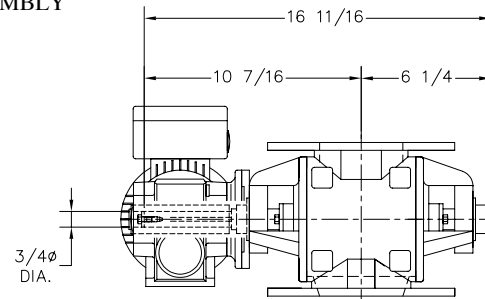

ELEVATION

VALVE INFORMATION					
HOUSING	ENDPLATE	ROTOR		BLADE TIP	
MAT'L	MAT'L	MAT'L	TYPE	MAT'L	CLEARANCE
C.I.	C.I.	MILD STEEL	FIXED EDGE	MILD STEEL	.003-.005

MOTOR						
MFG.	H.P.	VOLTAGE	ENCLOSURE	CL. & DIV.	FRAME SIZE	RPM
SEW EURODRIVE S-SERIES	1/3	T.B.A.	TEFC	STD. EFF.	DT71C4	1800

REDUCER				
MFG.	FRAME	RATIO	SIZE	R.P.M.
SEW EURODRIVE S-SERIES	SAF37	86.36	SAF37DT71C4	20

CHAIN DRIVE NOT REQ'D.			VALVE OPERATING CONDITIONS		
SIZE	BORE	SIZE	BORE	TEMP.	SEALS
---	---	---	---	AMBIENT	PACKING GLAND

CONVEYING INFORMATION	
PRODUCT HANDLED	TO BE ADVISED
PRODUCT DENSITY	TO BE ADVISED
DISPLACEMENT / REV. 100%	.025 C.F.R.
VALVE SPEED	FINAL RPM IS 20
CONVEY RATE	TO BE ADVISED

NOTES

- ALL DIMENSIONS IN INCHES
- CONSTRUCTION: CAST GREY IRON HOUSING AND ENDPLATES (CL,40,217 BRINELL) FABRICATED CARBON STEEL ROTOR, OPEN END FIXED WITH RELIEVED TIPS (1/8" LAND) CLOSE TOLERANCE C.C.W. ROTATION LOOKING AT THE DRIVE END.
- BOTTOM FLANGE BOLT PATTERN MATCHES TOP FLANGE PATTERN
- PAINT: STANDARD METAL PREPARATION, EXTERIOR PRIMED AND ONE COAT FINISH ENAMEL - ACS BLUE DRIVE GUARD IS HI-VISIBILITY SAFETY YELLOW, MOTOR/GEARMOTOR IS MANUFACTURES STANDARD FINSH
- ACST-4 SHAFT SEAL ASSEMBLY (SEE DETAIL)
- WEIGHT WITH DRIVE PACKAGE 315 LBS.
- INCLUDED OPTIONS:
 - ENDPLATES: CAST IRON CONSTRUCTION
 - ROTOR: 6-VANE FABRICATED OPEN END MILD STEEL
 - ROTOR: FIXED EDGE MILD STEEL ROTOR TIPS - BEVELED
 - HOUSING: CAST IRON CONSTRUCTION

Proprietary information
This drawing is the confidential property of Ancaster Conveying Systems Ltd. and transmitted in confidence. The reproduction, use or disclosure, in whole or in part, of the design or details contained herein is prohibited without the express written permission of Ancaster Conveying Systems Inc.

ANCASTER CONVEYING SYSTEMS LTD.
611 ARGYLE ST. N CALEDONIA ONTARIO N3W-1M1
TEL. (905) 765-2004 FAX. (905) 765-4491

TITLE: ACS MODEL 4" M.D. ROTARY VALVE, GENERAL ARRANGEMENT

FOR: GENERAL USE ONLY

P.O: N/A

SCALE: N. T. S.	DRAWN BY: G. T	B-3099
DATE: MAR/17/09	CHECKED:	

ISSUE	DATE	REVISION	BY