

PLAN VIEW

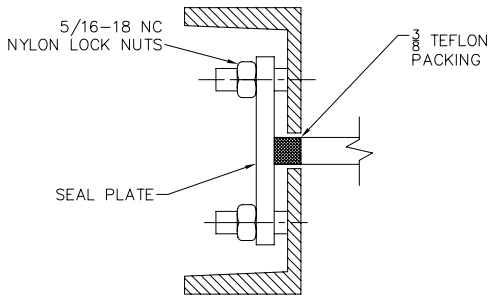

SECTION A-A

NOTES:

- ACS MODEL 6 X 6 MSG-S SQUARE SLIDE GATE FEATURES INCLUDE:
- 6 X 6 SQUARE INLET & OUTLET
 - DESIGNED FOR RATING 250°F MAX. SERVICE
 - 6" CRANK HANDLE
 - MILD STEEL C-CHANNEL FRAME
 - UHMW SLIDER GUIDES FOR 250°F MAX. SERVICE
 - 1/4" STAINLESS STEEL SLIDER PLATE
 - OPTIONAL BOLTED DUST COVERS
 - PAINT: PRIMED & PAINTED ONE COAT ACS BLUE
 - SHIPPING WEIGHT 60 LBS.

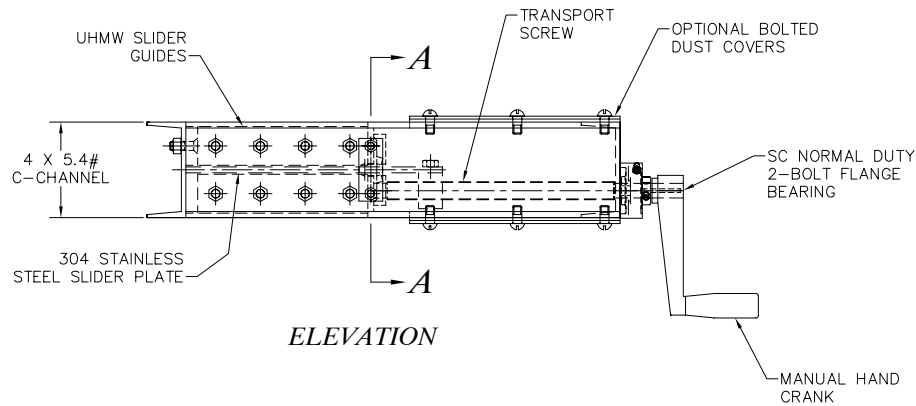

ELEVATION

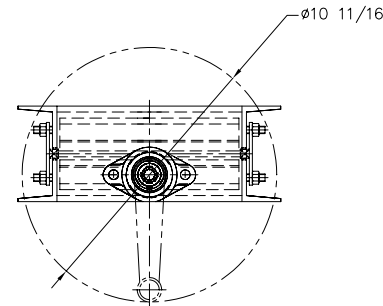

SIDE ELEVATION



ANCASTER CONVEYING SYSTEMS LTD.

611 ARGYLE ST. N CALEDONIA ONTARIO N3W-1M1
TEL. (905) 765-2004 FAX. (905) 765-4491

TITLE: ACS MODEL MSG 6 X 6 MAINTENANCE SLIDE GATE, GENERAL ARRANGEMENT

FOR: GENERAL USE ONLY

P.O: N/A

SCALE: N.T.S.	DRAWN BY: G.T
DATE: JAN/16/09	CHECKED:

B-408

Proprietary Information
This drawing is the confidential property of Ancaster Conveying Systems Ltd. and transmitted in confidence. The reproduction, use or disclosure, in whole or in part, of the design or details contained herein is prohibited without the express written permission of Ancaster Conveying Systems Inc.

ISSUE	DATE	REVISION	BY