

(6) $\phi 1 \frac{1}{8}$
DIA. HOLES &
(6) 1"-8 NC
TAPPED HOLES
ON 13 $\frac{1}{4}$ " B.C.D.

PLAN VIEW

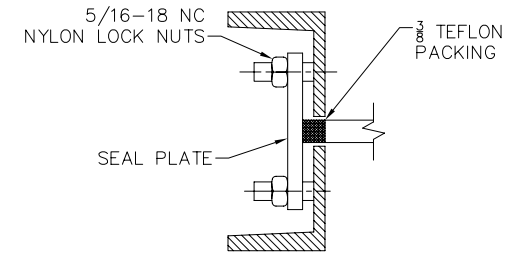

SECTION A-A

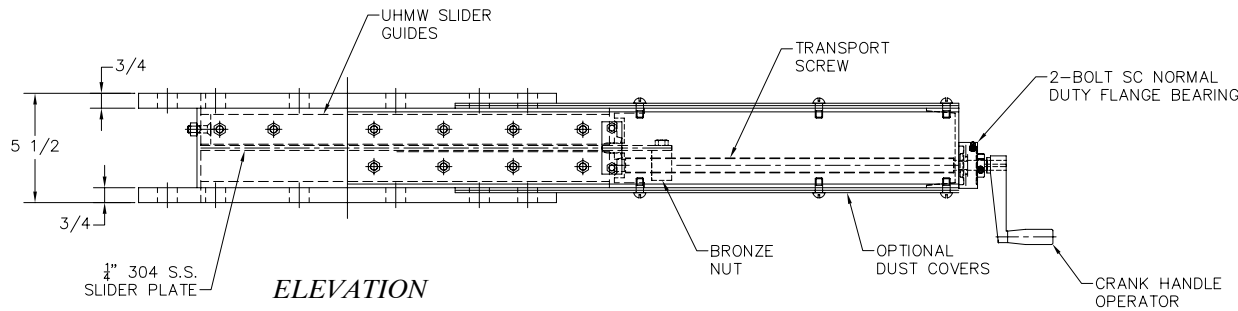

ELEVATION

NOTES:

- ACS MSG-R 14" ROUND MSG SLIDE GATE
FEATURES INCLUDE:
- 14" DIA. ROUND INLET & OUTLET
 - 14" 150# FLANGED BOLT PATTERN
 - 6" CRANK HANDLE
 - MILD STEEL C-CHANNEL FRAME
 - UHMW SLIDER GUIDES FOR 250°F MAX. SERVICE
 - $\frac{1}{2}$ " STAINLESS STEEL SLIDER PLATE
 - OPTIONAL DUST COVERS
 - PAINT: PRIMED & PAINTED ONE COAT ACS BLUE
 - SHIPPING WEIGHT 165 LBS.

ANCASTER CONVEYING SYSTEMS LTD.
611 ARGYLE ST. N. CALEDONIA ONTARIO N3W-1M1
TEL. (905) 765-2004 FAX. (905) 765-4491

TITLE: ACS MODEL MSG-R 14" MAINTENANCE SLIDE GATE, GENERAL ARRANGEMENT

FOR: GENERAL USE ONLY

P.O.: N/A

SCALE: N.T.S. DRAWN BY: G.T.
DATE: DEC/04/08 CHECKED:

B-802

Proprietary Information
This drawing is the confidential property of Ancaster Conveying Systems Ltd. and transmitted in confidence. The reproduction, use or disclosure, in whole or in part, of the design or details contained herein is prohibited without the express written permission of Ancaster Conveying Systems Ltd.

ISSUE	DATE	REVISION	BY